

Using the NCV7356 with Large Reservoir Capacitors

Prepared by: Frank Kolanko
ON Semiconductor



ON Semiconductor®

<http://onsemi.com>

APPLICATION NOTE

INTRODUCTION

The NCV7356 Single Wire CAN Transceiver provides the physical layer for digital communication using the CAN (Control Area Network) protocol. The General Motors Internal Specification GMW3089 is the GM Worldwide Engineering Standards document which must be observed to qualify for builds in modules within General Motors Corporation. Copies of GMW3089 must be obtained through General Motors Corporation, not ON Semiconductor. This application note involves system design outside the GMW3089 specification with suggestions when the capacitor connected between the VBAT pin and GND exceeds a 500 μF suggested value.

Typically, filter decoupling capacitors are used on the power supply input of an integrated circuit to provide buffering from unpredictable pc board resistive drops and inductance effects. This improves the overall system performance by reducing any induced signal on the supply pin coupling to an output thus improving the overall

rejection from extraneous signals. They are also used on voltage regulator outputs to supply instantaneous current when a power supply integrated circuit cannot respond fast enough to high current demands. While individual IC's will require different values for different reasons, it is common to see values which range from 100 nF to 100 μF (100 nF typical for an IC powered from a regulator and 100 μF more likely on the regulator output).

One reason to increase the size of this capacitor is to maintain circuit operation for short periods of time when power from the source has been temporarily interrupted. This is a common event where the power source in an automobile (VBAT) can be expected to droop down to as low as 6.0 V (as well as recent initiatives requiring a droop to 4.0 V) from a nominal 13.8 V during the engine crank cycle. Care must be taken when the system requirements for using the NCV7356 necessitate a capacitor value greater than 500 μF . This capacitor is commonly referred to as a reservoir capacitor because it is used to store energy to be used if the main source of power goes away.

AND8258/D

Typical Application

Figure 1 highlights a typical application circuit utilizing the NCV7356 which meets GMW3089.

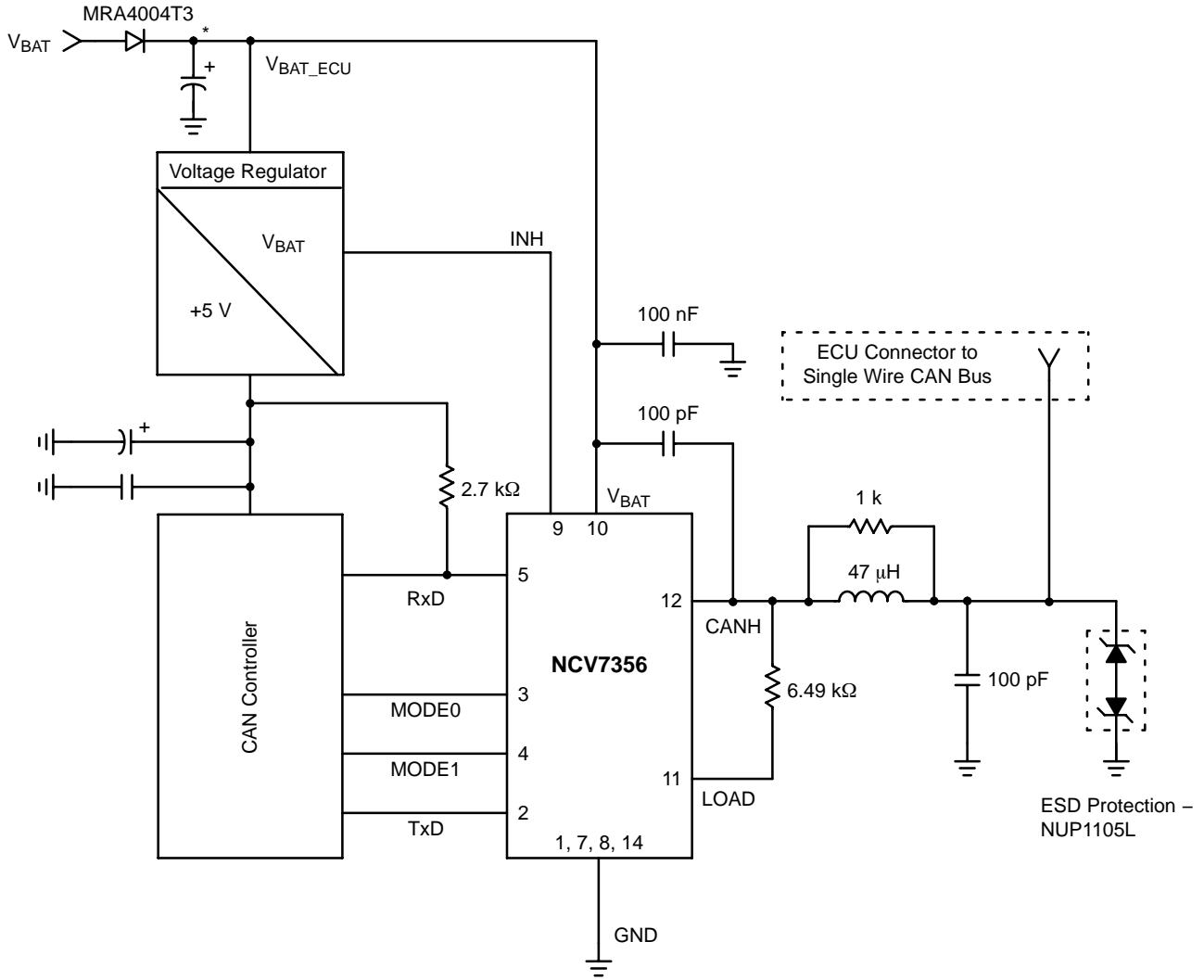

*Recommended capacitance at $V_{BAT_ECU} > 1.0 \mu\text{F}$ (immunity to ISO7637/1 test pulses)

Figure 1. Application Circuitry

Applications Requiring a Reservoir Capacitor

Generally, additional loading requirements will dictate the need for an additional reservoir capacitor. The need to maintain full operation of the NCV7356 which requires up to 35 mA of supply current in the Normal Mode, and up to 75 mA of supply current in the Wake-Up Mode, are not

feasible, as the reservoir capacitor would be quickly depleted, or would require an unreasonable value to sustain operation. A typical application would be to maintain memory circuits. The diagram below displays the addition of the reservoir capacitor.

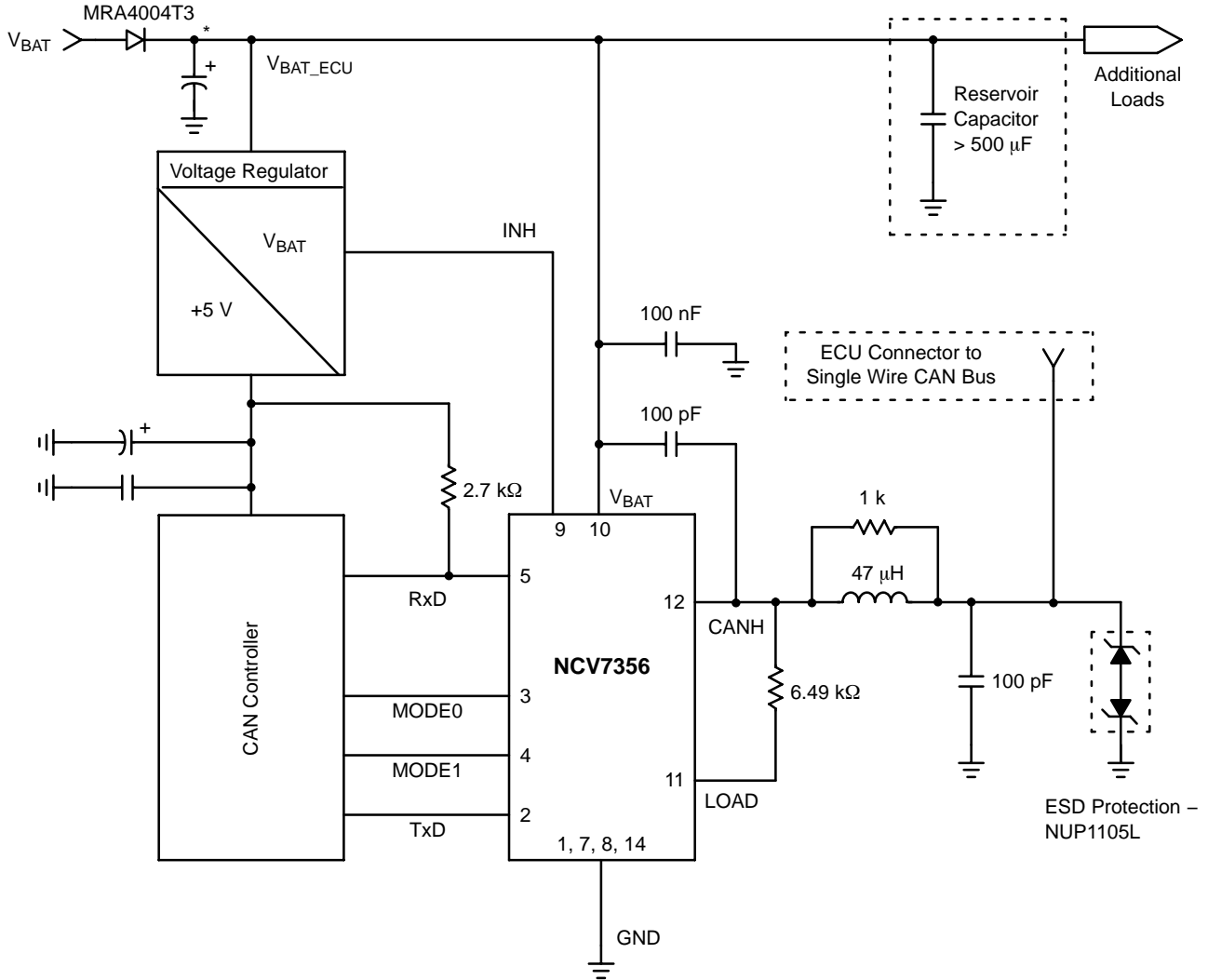

*Recommended capacitance at V_{BAT_ECU} > 1.0 µF (immunity to ISO7637/1 test pulses)

Figure 2.

It is worth noting the limitations of using a reservoir capacitor greater than 500 µF. The single known issue in GMLAN Device Test Specification GME6718GS is section 2.11.6 (Bus short to battery). Although tests involving the direct short from Vbat to the bus pin (CANH) pass (Test method 1), additional testing in section 2.11.6 (Test method 2) involves the emulation of a blown fuse and may result in damage. Specifically, when the power supply connected to Vbat in the diagram above is removed, and a

“short” (i.e. an additional power supply up to 26.5 V) is connected at the point in the circuit labeled “ECU Connector to Single Wire CAN Bus”, NCV7356 devices may be damaged with the following conditions.

- Reservoir Capacitor Values >500 µF
- Short rise times to the CANH pin
- Unlimited current limit of the applied voltage to CANH

Solutions for Reservoir Capacitors >500 μ F

Three solutions are available when there is a need to use a reservoir capacitor greater than 500 μ F.

Solution #1

The first involves adding a protection diode between the reservoir capacitor and the NCV7356. To comply with GMW3089, the added diode should provide a low forward

voltage drop. The MBR0530T1 Schottky diode is the suggested device. The original reverse battery diode (MRA4004T3) should also be replaced by a Schottky diode. The suggested device here is the MBRA130LT3. This device provides 30 V of reverse voltage protection. Additional protection can be added by using the MBRA160T3. This will provide 60 V of reverse voltage protection.

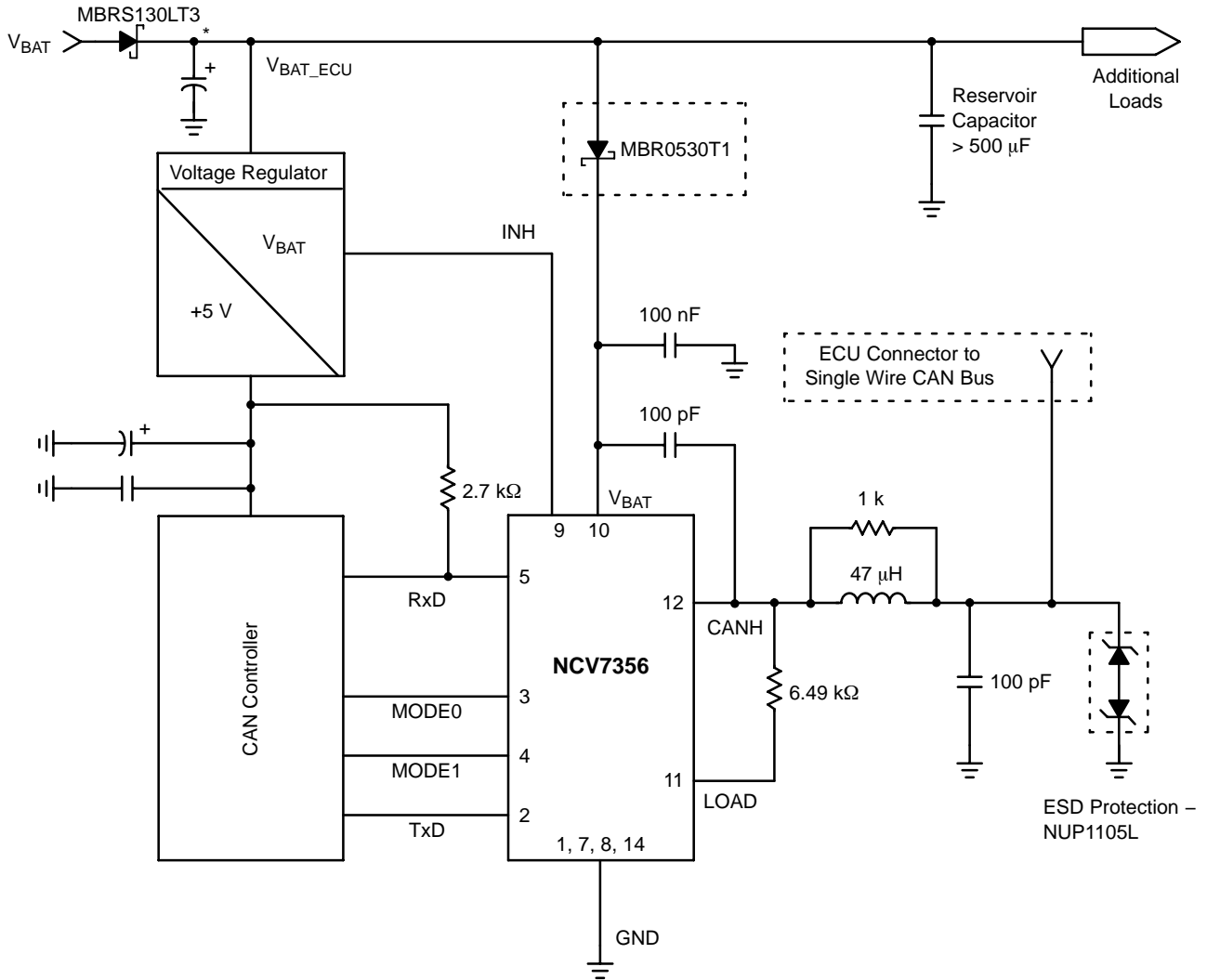

*Recommended capacitance at $V_{BAT_ECU} > 1.0 \mu$ F (immunity to ISO7637/1 test pulses)

Figure 3.

Solution #2

The second solution involves adding a 51 Ω resistor in series with the reservoir capacitor. In cases where the

reservoir capacitance consists of multiple capacitors, Solution #1 is recommended.

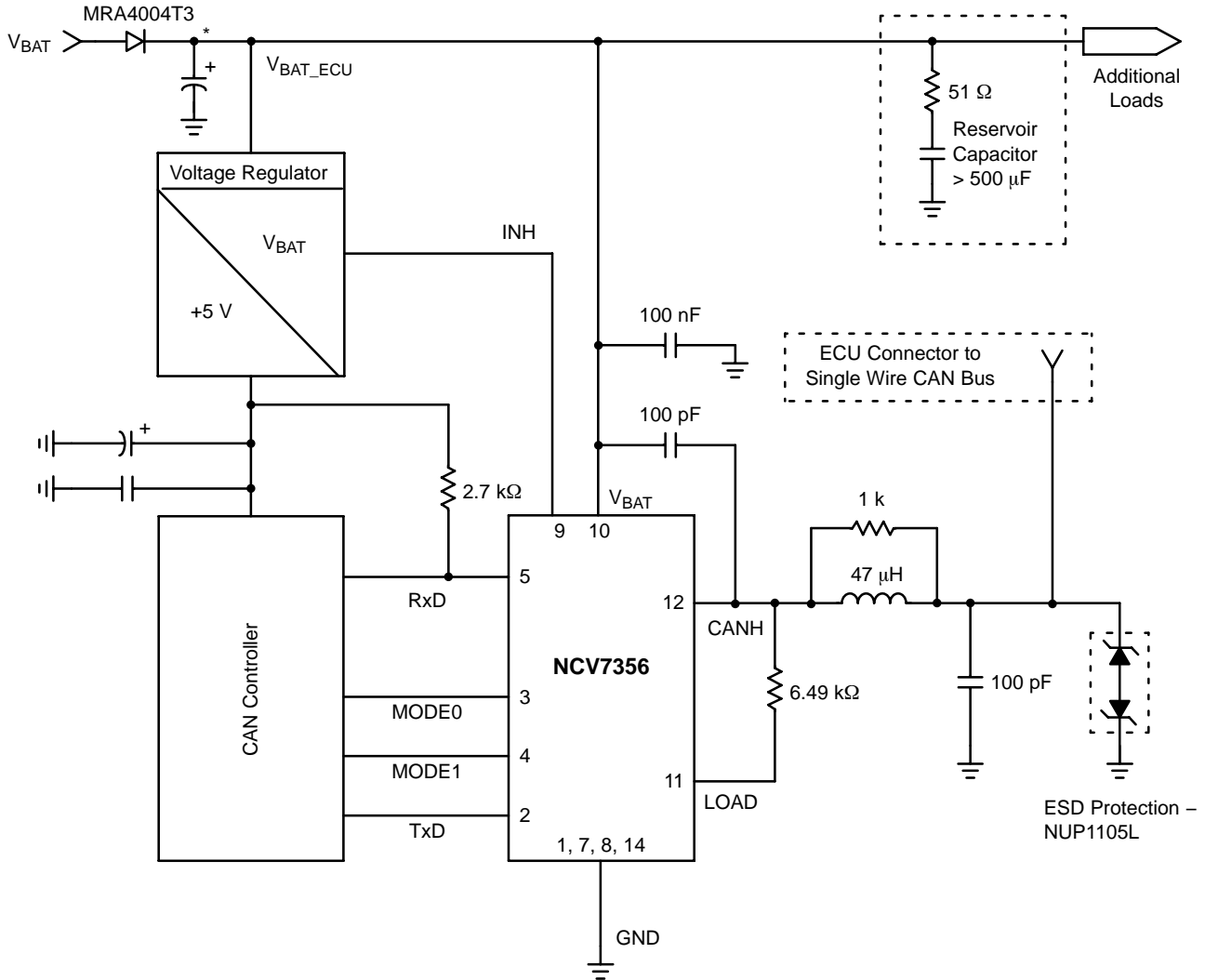

*Recommended capacitance at $V_{BAT_ECU} > 1.0 \mu F$ (immunity to ISO7637/1 test pulses)

Figure 4.

In normal operation the reservoir capacitor is charged through the 51 Ω resistor from power applied from Vbat through the reverse battery diode MRA4004T3. When Vbat is removed, power to the NCV7356 and to the additional loads is supplied through the 51 Ω resistor.

An application requiring 50 mA of additional loading would create an initial voltage drop across the 51 Ω created from the 50 mA load (2.55 V) plus the current loading of the NCV7356 and the voltage regulator.

The nominal quiescent current for the NCV7356 is 5.0 mA. We cannot pinpoint the magnitude of quiescent current of the voltage regulator or CAN controller loads because of the wide selection of components available.

Assume the quiescent current for the voltage regulator and its load is included in the additional loads group. The consideration for maintenance of supplied voltage simplifies to the initial charge on the Reservoir capacitor ($\approx 13 V$) being discharged by 55 mA (50 mA from the additional loads and 5.0 mA from the NCV7356).

The initial drop across the 51 Ω is 55 mA times 51 Ω or 2.805 V. This drop shows up immediately on the additional loads as $13 V - 2.805 V = 10.195 V$.

If we are to assume current source loading of 55 mA, the voltage supplied over time to the additional loads will be $V_{loads} = 10.195 V - (55 mA)(time)/(Capacitor Value)$.

AND8258/D

Solution #3

The third solution is an improvement over the aforementioned solution. This involves adding a diode in

parallel with the 51 Ω resistor. As in Solution #2, where the reservoir capacitance consists of multiple capacitors, Solution #1 is recommended.

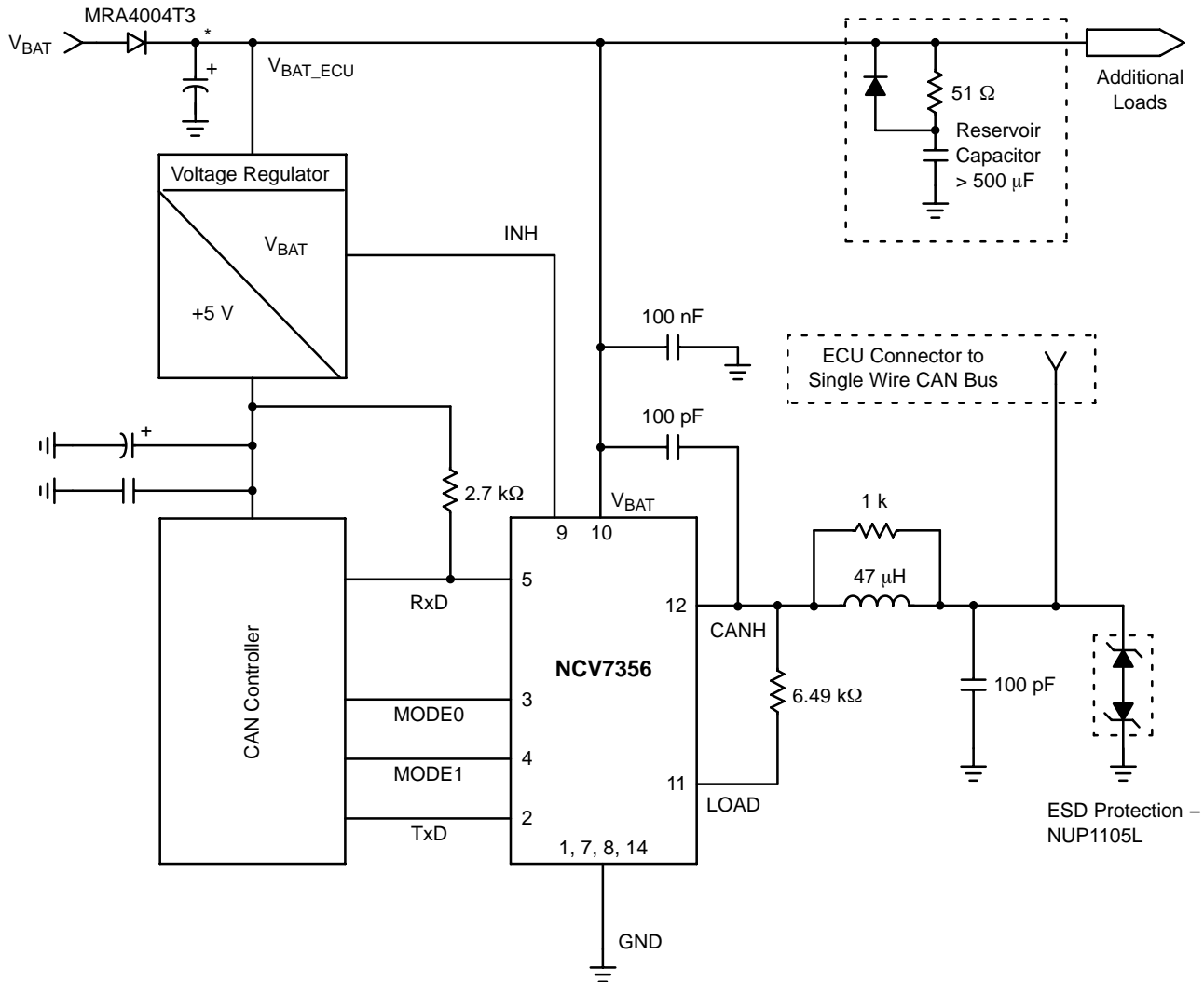

*Recommended capacitance at $V_{BAT_ECU} > 1.0 \mu F$ (immunity to ISO7637/1 test pulses)

Figure 5.

The benefit to this setup is the initial voltage drop previously mentioned (@2.805 V) has been reduced to the voltage drop of the diode. Assuming a voltage drop across the diode of 0.8 V there has been an increased voltage gain

of 2.005 V. Now the initial voltage drop is just 0.8 V, and the immediate voltage level is $13 V - 0.8 V = 12.2 V$.

This now changes the equation for calculation purposes to $V_{loads} = 12.2 V - (55 mA)(time)/(Capacitor Value)$.

AND8258/D

Summary

Three options are available when using the NCV7356 with reservoir capacitors greater than 500 μf .

1. Add a reverse protection diode.
2. Add a series resistor $>51 \Omega$ to the reservoir capacitor.
3. Add the series resistor from option 2 plus a parallel diode.

Selecting an option depends on each unique application for the NCV7356.

The benefits/detriments of each option are highlighted below.

Option #	Cost	Performance	
1	A	A	A = highest
2	C	C	B = low
3	B	B	C = lowest

Option 1 provides the best performance with the highest cost.

Option 2 provides an adequate solution, but current capability is limited to the charge on the reservoir capacitor passing through the added resistor.

Option 3 provides an improvement over Option 2 by improving the current capability being sourced through an added diode instead of limited by the resistor.

ON Semiconductor and **ON** are registered trademarks of Semiconductor Components Industries, LLC (SCILLC). SCILLC reserves the right to make changes without further notice to any products herein. SCILLC makes no warranty, representation or guarantee regarding the suitability of its products for any particular purpose, nor does SCILLC assume any liability arising out of the application or use of any product or circuit, and specifically disclaims any and all liability, including without limitation special, consequential or incidental damages. "Typical" parameters which may be provided in SCILLC data sheets and/or specifications can and do vary in different applications and actual performance may vary over time. All operating parameters, including "Typicals" must be validated for each customer application by customer's technical experts. SCILLC does not convey any license under its patent rights nor the rights of others. SCILLC products are not designed, intended, or authorized for use as components in systems intended for surgical implant into the body, or other applications intended to support or sustain life, or for any other application in which the failure of the SCILLC product could create a situation where personal injury or death may occur. Should Buyer purchase or use SCILLC products for any such unintended or unauthorized application, Buyer shall indemnify and hold SCILLC and its officers, employees, subsidiaries, affiliates, and distributors harmless against all claims, costs, damages, and expenses, and reasonable attorney fees arising out of, directly or indirectly, any claim of personal injury or death associated with such unintended or unauthorized use, even if such claim alleges that SCILLC was negligent regarding the design or manufacture of the part. SCILLC is an Equal Opportunity/Affirmative Action Employer. This literature is subject to all applicable copyright laws and is not for resale in any manner.

PUBLICATION ORDERING INFORMATION

LITERATURE FULFILLMENT:

Literature Distribution Center for ON Semiconductor
P.O. Box 61312, Phoenix, Arizona 85082-1312 USA
Phone: 480-829-7710 or 800-344-3860 Toll Free USA/Canada
Fax: 480-829-7709 or 800-344-3867 Toll Free USA/Canada
Email: orderlit@onsemi.com

N. American Technical Support: 800-282-9855 Toll Free
USA/Canada

Japan: ON Semiconductor, Japan Customer Focus Center
2-9-1 Kamimeguro, Meguro-ku, Tokyo, Japan 153-0051
Phone: 81-3-5773-3850

ON Semiconductor Website: <http://onsemi.com>

Order Literature: <http://www.onsemi.com/litorder>

For additional information, please contact your local Sales Representative.